

Svorník se závitem **typ MR-DUO**_(RD-DUO)

- materiál: A: ocel 4.8 (St37-3k) B: nerez 1.4301

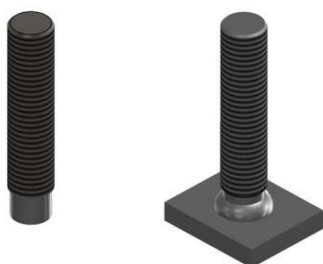

d ₁	l ₂	y _{min}	d ₂	d ₃	h
M8	15-100	4	6,2	9	2,5
M10	20-100	5	7,9	11,5	3
M12	20-100	6	9,5	13,5	4
M16	30-100	7,5	13,2	18	5

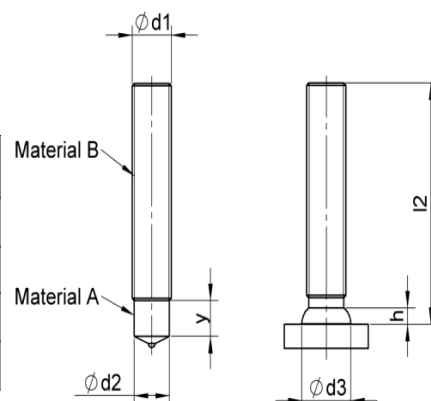

ROZMĚR SVORNÍKU

OBJEDNACÍ ČÍSLO

KERAMICKÝ KROUŽEK

KLEŠTINA

M8 x 15-100 mm

78-12-08-xxxx-R

RF-8

ARC - kleština pr.8mm

M10 x 20-100 mm

78-12-10-xxxx-R

RF-10

ARC - kleština pr.10mm

M12 x 20-100 mm

78-12-12-xxxx-R

RF-12

ARC - kleština pr.12mm

M16 x 30-100 mm

78-12-16-xxxx-R

RF-16

ARC - kleština pr.16mm



SPŘAHOVACÍ TRN typ SD1

- materiál: S355+C450

d ₁	l ₂	d ₅	k	d ₃	h
10	50-250	19	7,1	13	2,5
13	50-250	25	8	17	3
16	50-300	32	8	21	4,5
19	50-300	32	10	23	6
22	75-300	35	10	29	6
25	75-300	41	12	31	7

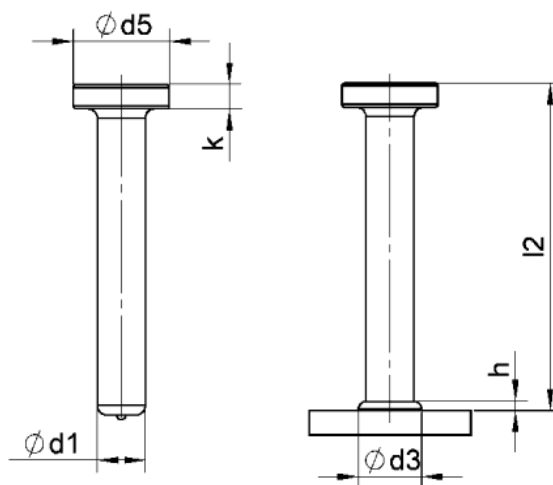

ROZMĚR TRNU

OBJEDNACÍ ČÍSLO

KERAMICKÝ KROUŽEK

KLEŠTINA

SD 10 x 50-250 mm

75-10-xxxx

UFN-10

ARC-kleština KB pr.10mm

SD 13 x 50-250 mm

75-13-xxxx

UF-13

ARC-kleština KB pr.13mm

SD 16 x 50-300 mm

75-16-xxxx

UF-16

ARC-kleština KB pr.16mm

SD 19 x 50-300 mm

75-19-xxxx

UF-19

ARC-kleština KB pr.19mm

SD 22 x 75-300 mm

75-22-xxxx

UF-22

ARC-kleština KB pr.22mm

SD 25 x 75-300 mm

75-25-xxxx

UF-25

ARC-kleština KB pr.25mm

ZPĚT NA KATALOG

